

ROTAX MAX

Technical Regulations 2023

Version 1

10 May 2023

1.	GENERAL	3
1.1	Categories	3
2.	ENGINE SEALING & SCRUTINEERING	3
3.	ENGINE MODIFICATIONS, REPAIRS & ADDITIONS	4
3.1	Modifications	4
3.2	Internal Additions	5
3.3	Legal Additions	5
3.4	Non-Technical Items	6
3.5	Measurements	6
4.	TECHNICAL SPECIFICATION WITHIN THE ENGINE SEAL FOR ROTAX MAX KART ENGINES	6
4.1	Squish Gap	6
4.2	Combustion Chamber Insert	6
4.3	Piston with Ring Assembly	7
4.4	Piston Pin	8
4.5	Cylinder	8
4.5.1	Cylinder Markings	8
4.5.2	Height of Cylinder	9
4.5.3	Cylinder Surfaces	9
4.5.4	Exhaust Port Shape	11
4.5.5	Exhaust Port Timing	11
4.6	Inlet System	11
4.6.1	Reed Valve Assembly	11
4.6.2	Inlet Manifold	12
4.7	Crankshaft	13



4.7.1	Con Rod	13
4.7.2	Ignition Signal on Crankshaft	13
4.7.3	Crankshaft Main Bearings	13
4.8	Balance Shaft	13
4.8.1	Crankcase	14
5.	TECHNICAL SPECIFICATION OUTSIDE THE ENGINE SEAL FOR ROTAX MAX KART ENGINES	14
5.1	Balance Drive	14
5.2	Centrifugal Clutch	14
5.2.1	Components	14
5.2.2	Clutch Dimensions	15
5.3	Combination of Ignition System, Carburettor and Exhaust System	15
5.4	Exhaust Valve Assembly (125 Senior MAX)	16
5.4.1	Distance of Exhaust Valve Flange at Cylinder to Piston	16
5.4.2	Impulse Nozzle	16
5.4.3	Exhaust Valve Setting	17
5.5	Ignition	17
5.5.1	Spark Plug	17
5.5.2	Spark Plug Cap	17
5.5.3	Pick-up	17
5.5.4	Ignition System	18
5.5.5	ECU	19
5.6	Battery, Battery Fixation and Wiring Harness	20
5.7	Intake Silencer	21
5.8	Carburettor	22
5.9	Fuel Pump	26
5.10	Fuel Filter	26
5.11	Radiator	26
5.12	Engine Coolant	28
5.13	Exhaust Socket (Restrictor)	28
5.14	Exhaust System	29
5.14.1	125 Micro MAX (Micro Cadet) & 125 Mini MAX (Inter) Exhaust	30
5.14.2	125 Micro MAX (Micro Cadet) Perforated Tube & Isolation Mat	31
5.14.3	125 Mini MAX (Inter) Perforated Tube & Isolation Mat	32
5.14.4	125 Junior MAX & 125 Senior MAX Exhaust	33

1. GENERAL

The Motorsport UK ROTAX Technical Regulations 2023 should be read in conjunction with the relevant Motorsport UK Karting Yearbook regulations as well as any relevant Championship Regulations and the relevant FIA/CIK Karting Articles. Anything which is not expressly allowed in these Technical Regulations or Motorsport UK Karting Yearbook / Championship Regulations is forbidden.

1.1 Categories

Engines used in the various Motorsport UK ROTAX classes are as follows:

- 125 Micro MAX (125 Micro Cadet) – Rotax Micro Cadet
- 125 Mini MAX (125 Inter) – Rotax Inter
- 125 Junior MAX – Rotax Junior Max
- 125 Senior MAX – Rotax Senior Max / 177 / 177 Masters

Note:

The 125 Junior MAX engine is the basis for the engine configurations 125 Micro MAX (125 Micro Cadet) and 125 Mini MAX (125 Inter). Only the deviations for 125 Micro MAX (125 Micro Cadet) and 125 Mini MAX (125 Inter) from the standard Technical Regulation for the 125 Junior MAX engine are defined.

The 125 Senior MAX engine is the basis for the engine configurations in the 125 Senior MAX 177 and 177 Masters classes with regards to all the component related regulations, except for class weight and driver's age.

2. ENGINE SEALING & SCRUTINEERING

Only engines that are supplied by JAG Engineering (the sole UK distributor of ROTAX Kart engines) are eligible for use.

Authorised Service Centres that are legal to check and seal engines are listed at:

https://jagrotax.co.uk/approved_rotax_centres/.

By sealing an engine, the Authorised Service Centres take over the responsibility for the conformity of the engine according to the valid Technical Regulations. Also, a brand-new engine must be checked according to the relevant Technical Specification before sealing.

Note:

Engines have to be sealed with specific JAG engine seals (black anodised aluminium seal with JAG logo plus a 6-digit serial number and barcode)

Only Seals with these markings are legal to be used in Motorsport UK events.



Note:

By means of the steel cable the engine must be sealed on one Allen screw [1] of the intake flange, on one stud screw [2] of cylinder and one Allen screw [3] of the cylinder head cover (see picture).

After sealing the engine the seal thread must be squeezed using calliper ROTAX 276110 (see picture of engine seal).

It is not allowed to pass the end of the sealing wire through the seal a second time (seals must be as shown in picture only).

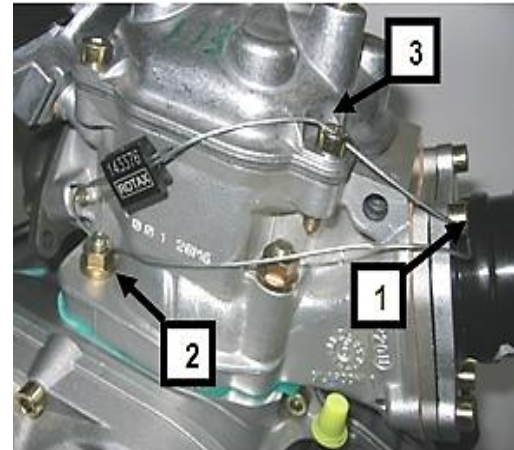

At every new sealing of an engine the ROTAX Authorised Service Centre that checks and seals the engine is responsible for following indications on the Engine Identity Card which belongs to the owner of the engine (see picture for example):

- Serial no. of the engine
- Serial no. of the engine seal
- Stamp and signature of the Authorised Service Centre.

At scrutineering the driver has to present:

- The engine(s) with the undamaged engine seal(s)
- The Engine Identity Card(s), showing the matching engine serial no.(s), the matching engine seal no.(s), the stamp(s) and signature(s) of the Authorised Service Centre that has checked and sealed the engine(s).

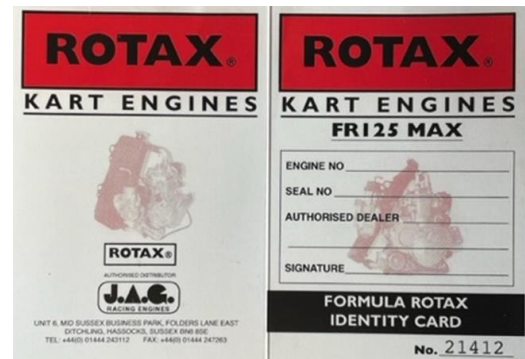
**Note:**

FOR ALL COMPONENTS OUTSIDE THE ENGINE SEAL, THE COMPETITOR IS RESPONSIBLE FOR ENSURING CONFORMITY WITH THE TECHNICAL REGULATIONS.

3. ENGINE MODIFICATIONS, REPAIRS & ADDITIONS

3.1 Modifications

Neither the engine nor any of its ancillaries may be modified in any way. "Modified" is defined as any change in form, content or function that represents a condition of difference from that originally designed. This is to include the addition and/or omission of parts and/or material from the engine package assembly unless specifically allowed within these rules. The adjustment of elements specifically designed for that purpose shall not be classified as modifications, i.e. carburettor and exhaust valve adjustment screws.

The repair of a thread on the crankcase (maximum of three threaded holes per crankcase) using a 'Heli-coil' or similar is allowed.

Exception: The threads located under the crankcase to fix the crankcase on the engine mount may be repaired as needed.

The repair of a thread on the cylinder (maximum of three threaded holes per cylinder) using a 'Heli-coil' or similar is allowed.

Genuine ROTAX components only that are specifically designed and supplied for the 125 Micro MAX (Micro Cadet), 125 Mini MAX (Inter), 125 Junior MAX and the 125 Senior MAX engine are legal, unless otherwise specified.

Note:

ANYTHING WHICH IS NOT EXPRESSLY ALLOWED IN THE TECHNICAL REGULATIONS IS FORBIDDEN.

3.2 Internal Additions

No additional material may be added except in the case of engine repairs and shall only restore the engine or components to original specifications.

The use of thermal barrier coatings/ceramic coatings on or in the engine and on or in the exhaust system is prohibited.

The use of anti-friction coatings in or on the engine/engine components is prohibited.

Example of allowed repairs (but not limited to):

Example 1: Damaged Cylinder due to freezing.

It is allowed to repair the cracked cylinder by welding.

It would also be allowed to dress/finish the area marked **red** to restore the part to the original specification.

It would not be allowed to dress/finish areas not affected by damage.



Example 2: Exhaust valve flange area repair.

Exhaust valve flange area (marked **red**) is damaged through contact wear with the exhaust valve.

It would be permitted to repair the **red** marked area only.



To dress or finish the area which was repaired in the **red** area would be allowed to ensure the engine is restored to its original specification.

Note:

Removal of additional, as supplied material from the surrounding areas is strictly forbidden.

3.3 Legal Additions

Chain guard, engine mount, temperature gauge and tachometer/hour meter, catch cans for liquids with mounting brackets.

Sensor for exhaust gas temperature (see exhaust systems).

3.4 Non-Technical Items

Non-original fasteners, circlips, washers, throttle cable housing, fuel and pulse line (type and size) as well as length of coolant hoses are allowed unless otherwise specified.

3.5 Measurements

When taking any dimensional reading, in accordance with the following Technical Regulations, in the order of accuracy of 0.10mm or even more precise, the temperature of the part must be between +10°C and +30°C.

Before taking any decision based on these Technical Regulations a check for available Bulletins or updates is mandatory.

- <https://www.motorsportuk.org/resource-centre/>
- <https://www.britishkartchampionships.org/official-documents/>

To avoid excessive noise and exhaust emissions revving the engine in the servicing park or paddock areas is not allowed.

4. TECHNICAL SPECIFICATION WITHIN THE ENGINE SEAL FOR ROTAX MAX KART ENGINES

4.1 Squish Gap

The crankshaft must be turned by hand slowly over top dead centre to squeeze the tin wire.

The squish gap must be measured on the left and right side in the direction of the piston pin. The average value of the two measurements counts.

Engine / Class		Squish minimum
125 Micro MAX (Micro Cadet) *	3mm tin wire (e.g. ROTAX 580132)	2.40mm
125 Mini MAX (Inter)	2mm tin wire (e.g. ROTAX 580130)	1.20 mm
125 Junior MAX	2mm tin wire (e.g. ROTAX 580130)	1.20 mm
125 Senior MAX / 177 / 177 Masters	2mm tin wire (e.g. ROTAX 580130)	1.00mm
125 MAX DD2 / Masters	2mm tin wire (e.g. ROTAX 580130)	1.30mm

** To achieve the defined minimum squish gap one spacer (ROTAX 626420, with same shape as cylinder base gasket) in combination with at least two cylinder base gaskets (one below the spacer and one above the spacer) must be used.*

4.2 Combustion Chamber Insert

Cast identification code must be one of the following:

- 223389
- 223389 1
- 223389 2
- 223389 2/1
- 223389 2/2

The profile of the combustion chamber insert has to be checked with a template (ROTAX 277390).

The crack of light between the template and the profile of the combustion chamber insert must be the same over the whole profile.



Casted wording "ROTAX" and/or "MADE IN AUSTRIA" must be shown.



	Measurement	Tolerance
Height of combustion chamber insert [H]	28.80mm	+0.10mm -0.10mm

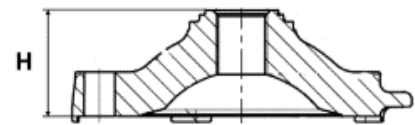

4.3 Piston with Ring Assembly

Original, coated, aluminium, cast piston with one piston ring. The piston has to show on the inside the cast wording "ELKO" [1] and "MADE IN AUSTRIA" [2].

Machined areas are:

- Top end of piston
- Outside diameter
- Groove for the piston ring
- Bore for the piston pin
- Inside diameter at bottom end of piston and some pre-existing factory removal [3] of flashing at the cut out of the piston skirt.

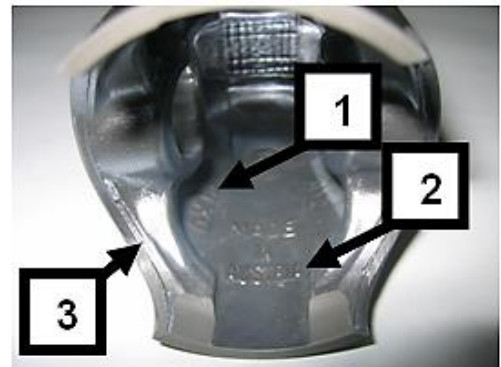

All other surfaces are not machined and have cast surface.

Any mechanical treatment or rework of the piston is forbidden (altering the pistons profile by reworking carbon build-up is forbidden, if carbon is removed it must be consistently removed across the entire surface without altering the profile of the piston itself).

Example: selectively removing carbon in the squish measurement areas is forbidden.

Original, magnetic, rectangular piston ring.

	Measurement	Tolerance
Ring height	0.98mm	+0.02mm -0.02mm



Piston ring is marked with one of the following:

- ROTAX 215547
- ROTAX 215548
- ROTAX 215548 X
- ROTAX 215548 X

The piston ring is legal also if just parts of the marking are still visible.

4.4 Piston Pin

Piston pin is made out of magnetic steel. Dimensions must be according to the drawing.

The minimum weight of the piston pin must not be lower than 31.00 grams.

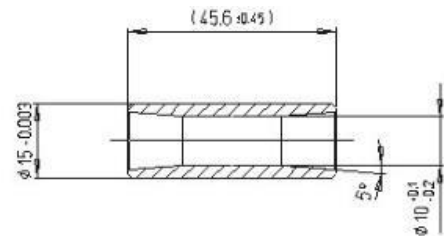

4.5 Cylinder

Light-alloy-cylinder with GILNISIL plating. Any re-plating of cylinder is not allowed.

Maximum bore of cylinder: 54.035mm (measured 10mm above the exhaust port).

4.5.1 Cylinder Markings

Cylinder has to be marked with the "ROTAX" logo (see pictures below):

125 Micro MAX (Micro Cadet), 125 Mini MAX (Inter) and 125 Junior MAX:

Cylinder with one main exhaust port and without exhaust valve.

Cylinders marked with identification code 223994 only are legal to be used.



125 Senior MAX:

Cylinder with one main exhaust port and exhaust valve.

Cylinders marked (cast or machined) with identification code 223993 only are legal to be used.



4.5.2 Height of Cylinder

Measured with a digital calliper min. length 200mm.

	Measurement	Tolerance
Height of cylinder	87.00mm	+0.10mm -0.05mm

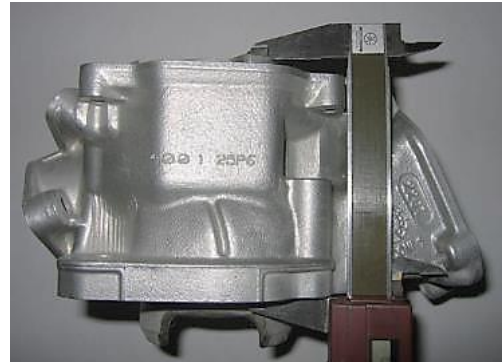

4.5.3 Cylinder Surfaces

All transfer ports and passages have cast finish surface except some removal (done by the manufacturer) of cast burr at the inlet passage, exhaust port and passages. All ports have chamfered edges to prevent ring snagging. Any additional machining is not permitted.

The top edge of exhaust port may show some pre-existing machining from the manufacturer. The sealing flange for the exhaust socket may show signs of machining from the manufacturer.

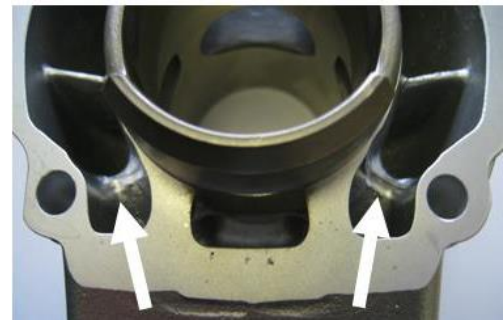

Important:

All ports have chamfered edges. Any additional machining is not permitted (below left picture).

Cylinders marked 223993, 223994 and 613933 the upper edge of the central boost port may show factory machining (below centre picture).

The flange for the exhaust socket may show either cast finish or machined surface. Machined surface can be either flat or show a circular sealing bump (below right picture).

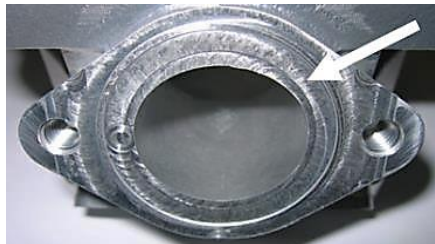
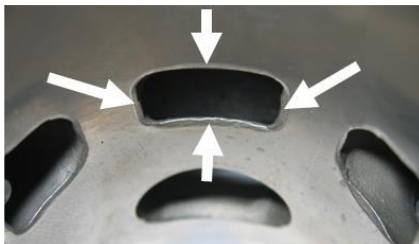

The top edge of the exhaust port may show either just a cast finish surface (left picture) or signs of CNC machining (central picture) or signs of CNC machining in combination with signs of manual grinding (right picture).



The exhaust port may show partial manual grinding done by the manufacturer to eliminate minor casting defects and/or to eliminate the NIKASIL burr at the end of the NIKASIL plating (see above right picture).

Single Core Cylinder marked J or V:

Cylinders marked 223994 and 223993 may show in the inlet port a linear texture.

Cylinders marked 223994 and 223993 with linear texture in the inlet port show a fully CNC machined exhaust port and a fully CNC machined top edge of the central boost port.

Cylinders marked 613933 may show in the inlet port a linear texture.

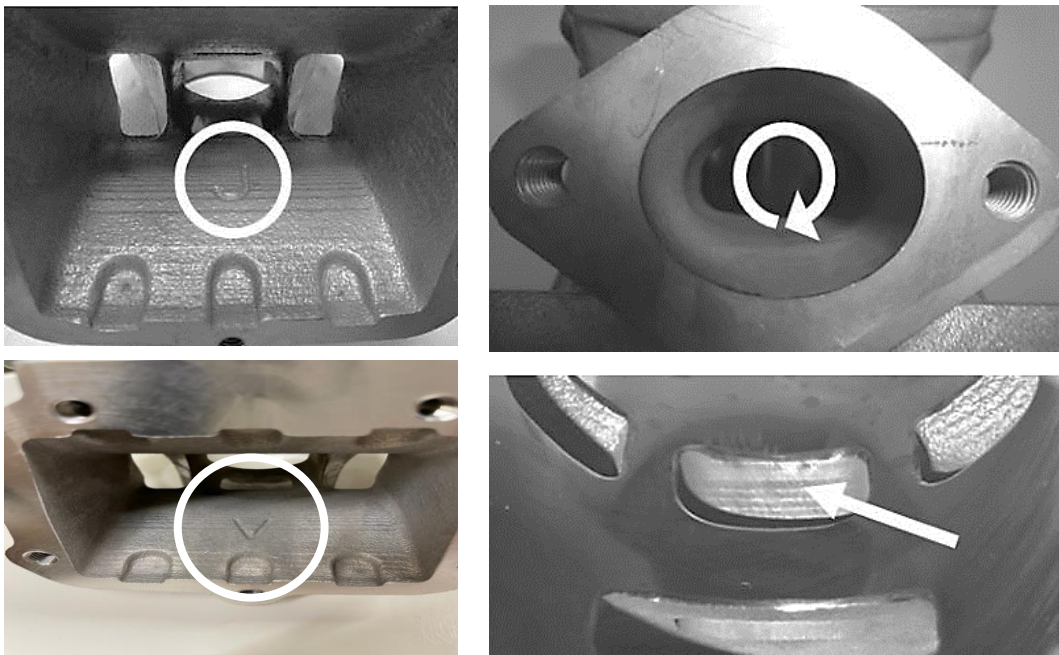

Single core cylinder

Linear structured cast finish surface

Old type smooth cast finish

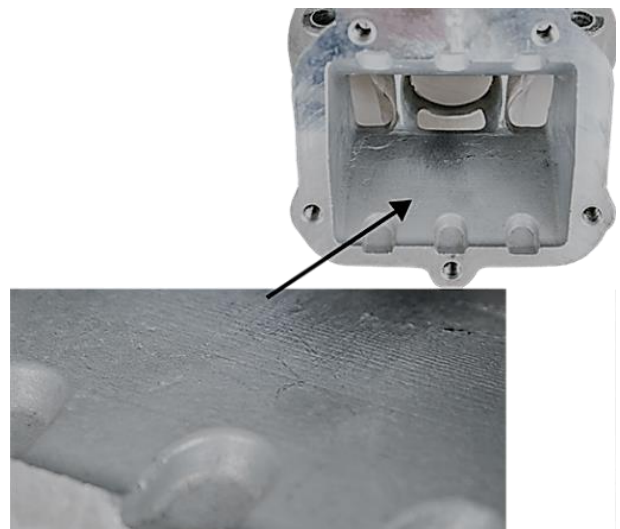

4.5.4 Exhaust Port Shape

Cylinder 223994 with fully CNC machined exhaust port only:

The horizontal and vertical dimensions of the exhaust port have to be checked with the template ROTAX 676240.

Cylinder 223993 with fully CNC machined exhaust port only:

The horizontal and vertical dimensions of the exhaust port have to be checked with the template marked with 676245*.

The template must be moved in horizontal and vertical Position as far as possible into the exhaust port.

In both directions, the template may not touch the flange for the exhaust socket.

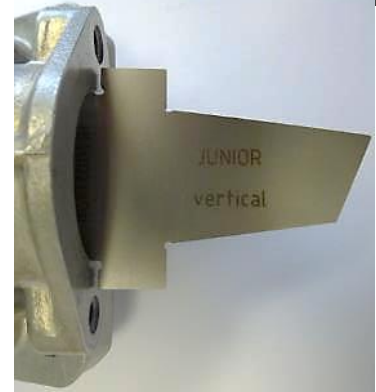

4.5.5 Exhaust Port Timing

The "exhaust port timing" (distance from the top of the cylinder to the top of the exhaust port) has to be checked by means of the template (ROTAX 277402).

Insert the template into the cylinder and move the template (at the highest point of the exhaust port) as far as Possible into the exhaust port. In this Position the template may not touch the cylinder wall.



Take care to use the correct gauge for:

- Junior MAX (Junior template to be used for Micro MAX (Micro Cadet) and Mini MAX (Inter))
- Senior MAX

4.6 Inlet System

4.6.1 Reed Valve Assembly

The reed valve assy. is equipped with 2 petal stops and 2 reeds, each having 3 petals.

	Measurement	Tolerance
Thickness of reeds	0.60mm	+0.10mm -0.10mm



Flattening of the curved reed valve stopper plates is forbidden.

With effect from 20 June 2023:

The minimum gap between the 2 curved stopper plates must be greater than 17.00mm.

The measurement must be taken using a digital calliper from the inside surface of the stopper plates in line with the middle of each reed petal, as indicated by the red lines in the picture.

125 Micro MAX (Micro Cadet) and 125 Mini MAX (Inter):

It is mandatory to add 2 additional ‘distance plates’ (ROTAX 281551) to the reed block assembly.

One ‘distance plate’ must be secured tightly between the reed petals and the curved stopper plate on each side of the reed assembly and in the order as show in the diagram. The “ROTAX” markings must be facing the stopper plate as shown in the diagram.

The 2 distance plates must be engraved “ROTAX” (as per the drawing below) with the part number 910224380 visible on the plate.

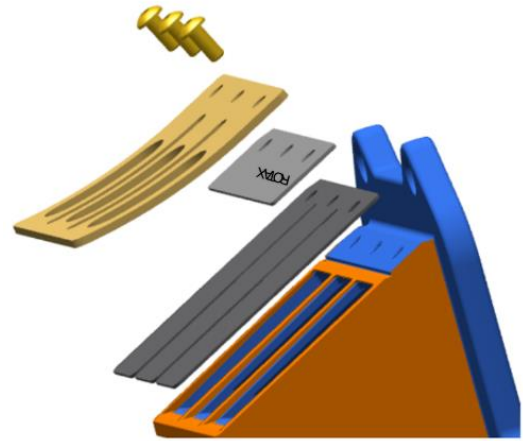

The plate must be flat with no curvature, when held against a straight edge no crack of light should be visible between the two surfaces, and meet the below specification.

It is mandatory to install 2 gaskets between the reed block assembly and the cylinder.

It is mandatory to fit one M6 washer under the bolt which is secured with the sealing wire for identification purpose.

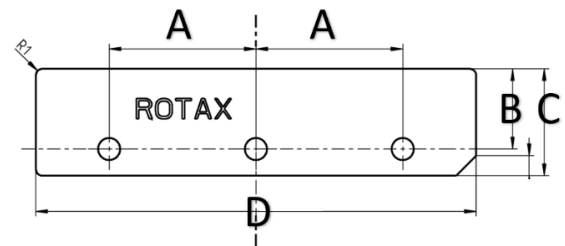

	Measurement	Tolerance
A	22.00mm	+0.20mm -0.20mm
B	10.00mm	+0.30mm -0.30mm
C	16.00mm	+0.30mm -0.30mm
D	66.00mm	+0.70mm -0.70mm

	Measurement	Tolerance
Distance plate thickness	0.70mm	+0.08mm -0.08mm
Location holes	3.30mm	+0.20mm -0.20mm

4.6.2 Inlet Manifold

Some factory flash removal may be present at the conjunction of the inside contour and the carburettor stop mounting face. This is a manual trimming operation consisting of a small corner break of less than 3mm in width. No additional grinding or machining is permitted.

Inlet manifold marked with the identification code “267915” and the name “ROTAX” or just “267916”.



4.7 Crankshaft

4.7.1 Con Rod

	Measurement	Tolerance
Stroke	54.50mm	+0.10mm -0.10mm

Con rod has to show forged numbers "213", "365", "367" or "362" on shaft.

Shafts of con rods "213", "365" and "367" are not machined and are copper plated.

Shaft of con rod "362" is not copper plated and is blank (grey/brown).

Grinding or polishing of shaft of con rod is not permitted.



4.7.2 Ignition Signal on Crankshaft

Fit the template (ROTAX 277391) on the crankshaft.

Align the hole in the template for the big end pin with the big end pin of the crankshaft.

The two edges of the signal machining on the crankshaft must be in line ($\pm 0.5\text{mm}$) with the corresponding edges (marked "MAX") of the template.



4.7.3 Crankshaft Main Bearings

Crankshaft main bearing 6206 from FAG is allowed only.

Must be marked with code 579165BA, Z-579165.11.KL or Z-579165.21.KL

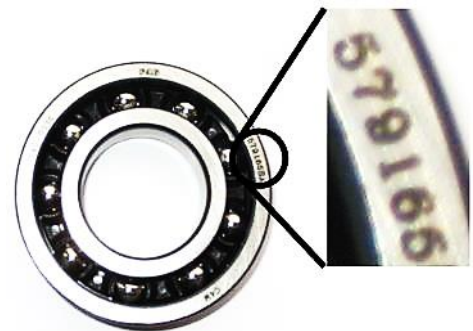

4.8 Balance Shaft

Balance shaft and balance gears must be installed.

Balance shaft must show casting code 6237948 or 6237949 on surface (1).

Surface (1) is not machined and must show cast surface.

The minimum weigh of the dry balance shaft must not be lower than: 255 grams.

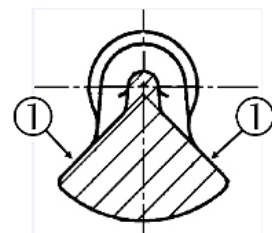

4.8.1 Crankcase

As supplied by the manufacturer.

No grinding/polishing is permitted in the two main transfer passages as well as in the crank area.

Machining maybe evident in the crankcases in the area identified in the picture.

For Micro Max (Micro Cadet) and Mini Max (Inter) classes only black coated crankcases from engine number 8626234 onwards and individual crankcase numbers 6211885 (ignition sensor side) and 6211893 (clutch side) are eligible for use

For all other classes uncoated or black coated crankcases are legal to be used.

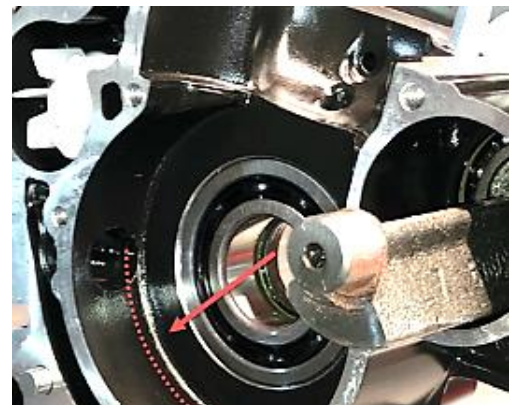

5. TECHNICAL SPECIFICATION OUTSIDE THE ENGINE SEAL FOR ROTAX MAX KART ENGINES

It is the responsibility of the competitor to check their equipment (all components outside the engine seal as mentioned below), to ensure that their equipment is conforming to the technical specification below.

5.1 Balance Drive

Steel balance gears only (minimum width 8.8 mm) are legal to be used.

Balance gears must be installed and must be aligned according to the instruction in the repair manual.

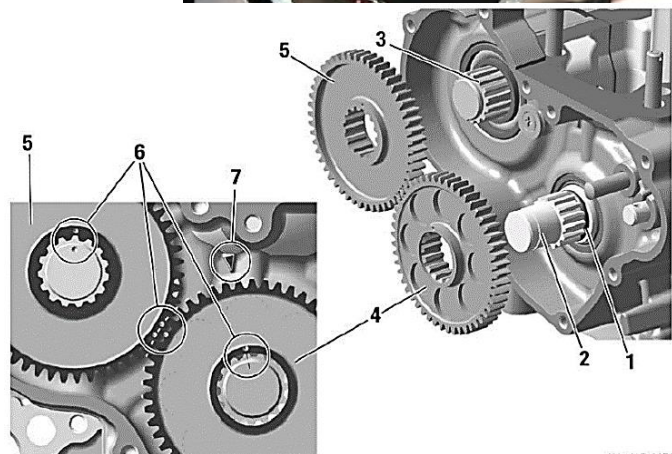

KA_125_0270

5.2 Centrifugal Clutch

5.2.1 Components

Engagement speed of centrifugal clutch at maximum 4000rpm (the kart with driver must start to move).

Two versions of clutch (item (1), with and without holes) are legal to be used.

Both versions are marked with the wording “ROTAX”.

O-ring (2) must be fitted and must ensure an appropriate sealing between the clutch drum and the needle/plain bearing.

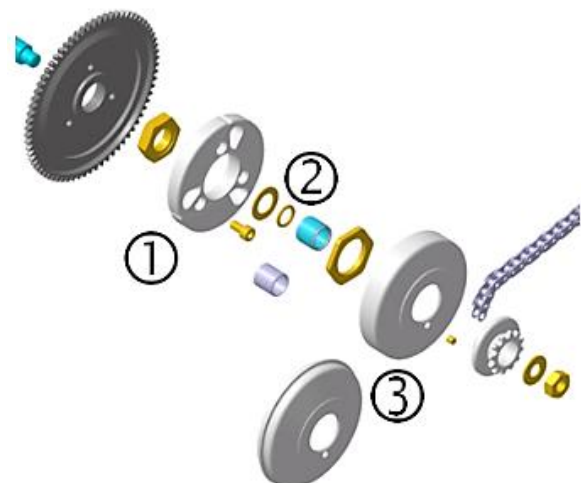

Two versions of clutch drum (3) are legal to be used.

Both versions are marked with the wording “ROTAX”.

Signs of emission of grease or substance from the needle/plain bearing into the clutch drum may not exceed the picture here.



Contact area between clutch and clutch drum has to be dry at any time – no lubrication allowed.

5.2.2 Clutch Dimensions

Thickness of clutch shoe [A]: Minimum 24.10mm.

Measurement must be carried out at the 3 open ends of the clutch, 5-10 mm from the machined groove (all clutch shoes must be completely closed at measurement – no gap).

Width of clutch [B]: Minimum 11.45mm.

Clutch drum Outer diameter [C]: Minimum 89.50mm.

Diameter must be measured with a sliding calliper just beside the radius from the shoulder (not at the open end of the clutch drum).

Clutch drum Inner diameter [D]: Maximum 84.90mm.

Diameter must be measured with a sliding calliper. The measurement must be carried out in the middle of the clutch drum (in the contact area between clutch and clutch drum).

Clutch drum Height [E] with sprocket/primary gear: Minimum 33.90mm.

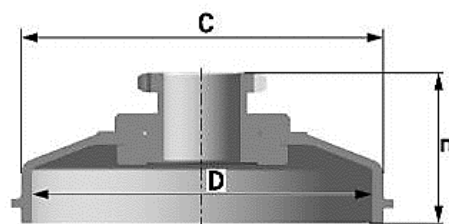
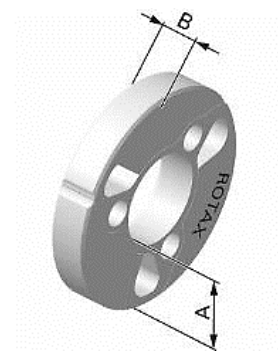

5.3 Combination of Ignition System, Carburettor and Exhaust System

The combination of components is limited to following specification per engine type:

	Micro	Mini	Junior	Senior
Ignition system Dell’Orto	✓	✓	✓	✓
Exhaust valve, electronically timed	-	-	-	✓
Carburettor XS	✓	✓	✓	✓
Exhaust system EVO	✓	✓	✓	✓

5.4 Exhaust Valve Assembly (125 Senior MAX)

System must be used with all components fitted as shown in the illustration.

The cylinder protection plate (45) can (ROTAX 251336) be installed and must have a minimum thickness of 0.08mm.

With effect from 20 June 2023:
The cylinder protection plate (45) (ROTAX 251336) must be installed and must have a minimum thickness of 0.08mm.

It is possible for the cylinder protection plate (45) to show signs of wear or damage.

Bellow (10) must have green colour.

Exhaust valve (2) dimensions:

	Measurement	Tolerance
Height	36.50mm	+0.20mm -0.30mm
Width of collar	4.80mm	+0.30mm -0.30mm

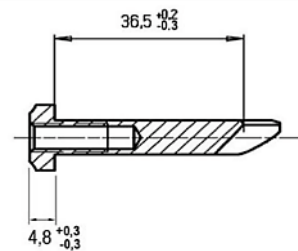
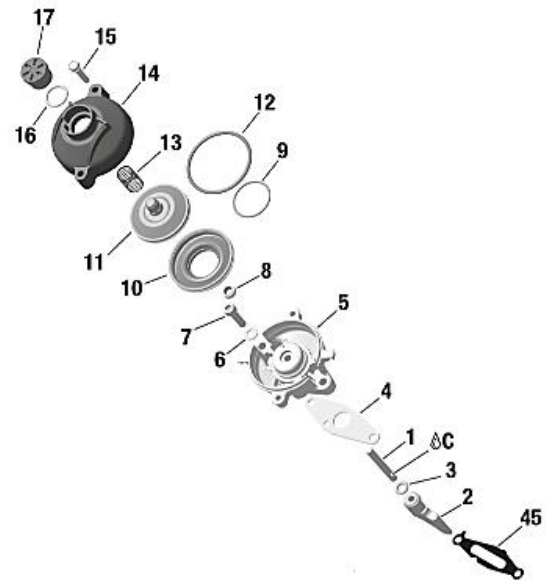

5.4.1 Distance of Exhaust Valve Flange at Cylinder to Piston

Turn crankshaft until the piston just closes the exhaust port. Insert the exhaust valve gauge (ROTAX 277030) as shown in the picture until it stops at the flange.

At the contact area between exhaust valve gauge (ROTAX 277030) and the flange of the cylinder, a feeler gauge 0.05mm must not fit between the gauge and the flange.

The measurement must be performed outside the exhaust valve contact area indicated in red.



5.4.2 Impulse Nozzle

Fitting an original impulse nozzle (1) into the pressure hose is an allowed adjustment.

The direction of the impulse nozzle inside the pressure hose is free.

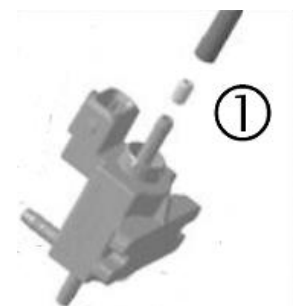

5.4.3 Exhaust Valve Setting

The electronic timed exhaust valve offers two different settings (A) or (B) for the opening of the exhaust valve.

(A) additional ground cable not connected

(B) additional ground cable connected

Both settings are legal to be used.

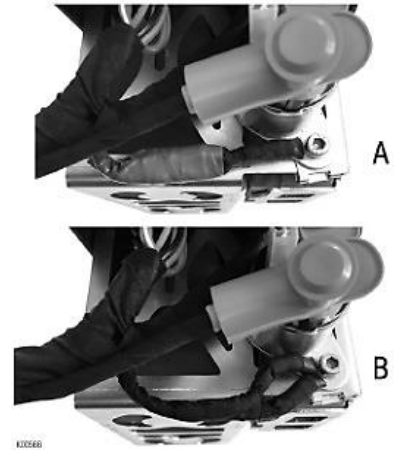

5.5 Ignition

Digital battery ignition system, variable ignition timing, no adjustments possible.

5.5.1 Spark Plug

125 Micro MAX (Micro Cadet) and 125 Mini MAX (Inter):

Spark plug: NGK GR8D1 or GR9D1

Electrode gap (maximum): Feeler gauge 1.20mm must not fit in between the two electrodes.

125 Junior MAX, 125 Senior MAX:

Spark plug: NGK GR8D1 or GR9D1, or DENSO IW27, IW29 or IW31

Electrode gap (maximum): For NGK spark plugs:
Feeler gauge 1.00 mm must not fit in between the two electrodes.

5.5.2 Spark Plug Cap

Two versions of the spark plug cap are legal to be used. Red or black, marked “NGK” or “ROTAX”.



5.5.3 Pick-up

The marking of the pick-up must show the following numbers in the first line 029600-0710.

A steel ball (diameter 3-5mm) placed on circular surface of the sensor must stay in the centre of the circular surface.

For 125 Junior MAX and 125 Senior MAX only:

Mounting the pick-up to the crankcase with a maximum of two gaskets (ROTAX 431500 – thickness 0.8mm) additional to the original rubber sealing ring of the pick-up, is permitted.

Fitting Position of the additional gasket(s):

Crankcase – rubber sealing ring – additional gasket(s) – pick-up.

Note: It is not necessary to install any additional gasket/s with the exception of the rubber sealing ring on crankcases with the machined sealing surface for the pick-up sensor.



5.5.4 Ignition System

Only the Dell'Orto ignition system is legal to be used.

Officials may request at any time that the competitor replaces the electronic box (ECU) with another unit provided by the Officials.

The visual appearance of the ignition coil must be identical with the pictures.

Ignition coil must show 2 pins at the terminal.

The ignition coil is still legal to be used also if one or both stickers are faded or removed.

Minimum length of the high tension cable of the ignition coil is 210mm (from outlet of ignition coil to outlet of spark plug connector = visible length of cable).

Ignition coil (same for all engines) with separate electronic box (ECU, specific for every engine).

Ignition coil and ECU (and magnet valve, for 125 Senior MAX only) must be fitted with all components according to the illustrations below.

In case the mounting bracket is in conflict with a chassis component, the additions of 2 spacers, one per mounting hole, with a maximum thickness of 20mm between the mounting bracket and the gearbox cover is allowed.



5.5.5 ECU

The electronic control unit (ECU) is labelled with stickers and is still legal also if the sticker is unreadable or disappeared.

125 Micro MAX (Micro Cadet): “666815”

125 Mini MAX (Inter): “666818”

125 Junior MAX: “666813”

125 Senior MAX: “666815”

The ECU must be checked with the ECU tester (ROTAX 276230) according to following procedure.

Disconnect engine cable harness from ECU.

Connect ECU tester cable harness to ECU.

Connect energy cable of ECU tester cable harness with the charging connector of engine cable harness.

At every connection with the battery the software version of the ECU tester will be indicated on the display for approx. 2 seconds.

The software version indicated on the display must be 2V00.

Start the test by pressing the button “✓” on the ECU tester.

After approx. 3 second the type of ECU ① that is actually tested will be indicated in the second line of the display.

After approx. 30 seconds the result ② of the test will be indicated in the first line of the display.

The ECU tester must indicate following results:

125 Micro MAX (Micro Cadet):

① 666815MAX

② !! Test OK !!

125 Mini MAX (Inter):

① 666818MINI

② !! Test OK !!

125 Junior MAX:

① 666813JNRMAX

② !! Test OK !!

125 Senior MAX:

① 666815MAX

② !! Test OK !!



5.6 Battery, Battery Fixation and Wiring Harness

Original batteries with following specification only are legal to be used:

YUASA YT7B-BS or YUASA YT7B
(with and without Rotax branding)

ROTAX RX7-12B or RX7-12L or ROTAX LiFePo4
(lithium iron phosphate type)

Battery must be fitted with an original battery clamp and battery cover (according to illustrations) and must be fixed to the chassis with both clamps (all 4 screws). Battery clamp with or without cable support is legal for use.

Battery clamp must be mounted on the left side of the chassis, next to the seat.

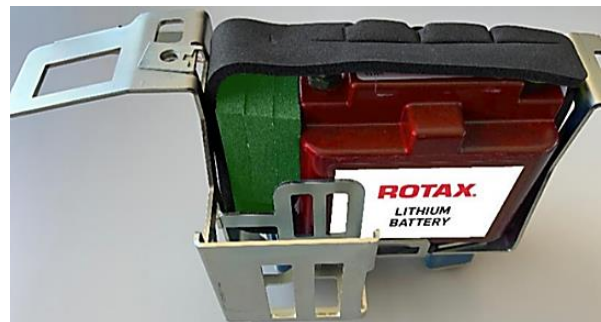
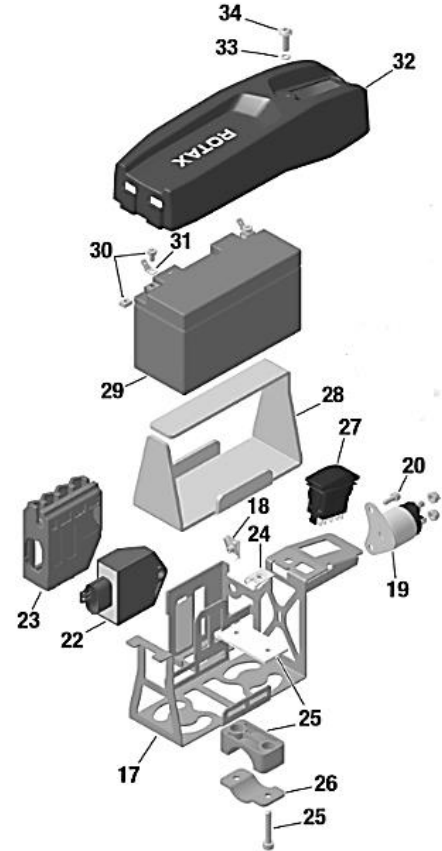

Two versions of the wire harness are allowed to be used. The differences between the two versions can easily be identified by the key points listed.

	Wiring Harness (666 835)	Wiring Harness (666 836)
ECU Connector		

	Wiring Harness (666 835)	Wiring Harness (666 836)
Charging Connector		
Solenoid Connector		

5.7 Intake Silencer

Intake silencer with integrated, washable air filter must be used with all parts as shown at the illustration and has to be mounted on the support bracket with two screws (in dry and wet condition).

Intake silencer tube (2) and carburettor socket (6) are marked with the wording "ROTAX".

Intake silencer case bottom is marked on the inside with "225015".

Intake silencer case, top is marked on the inside with "225025".

Two versions of original air filters (4) are legal to be used. Double layer air filter (green/orange), double layer air filter (green/dark green) marked "Twin Air". Depending on the degree of oil-lubrication colours may alter slightly or the surface becomes stained (see examples).

Air filter (4) must be installed as shown in the illustration between the two holders (3) and must cover the complete area of the intake silencer case bottom (1).

During wet condition, it is not permitted to attach anything to the air box to protect the air inlet from water spray.

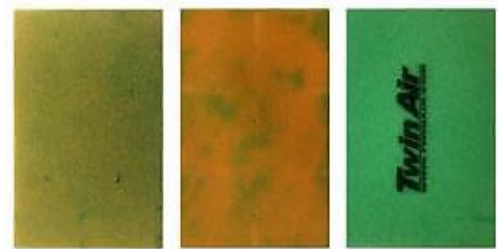
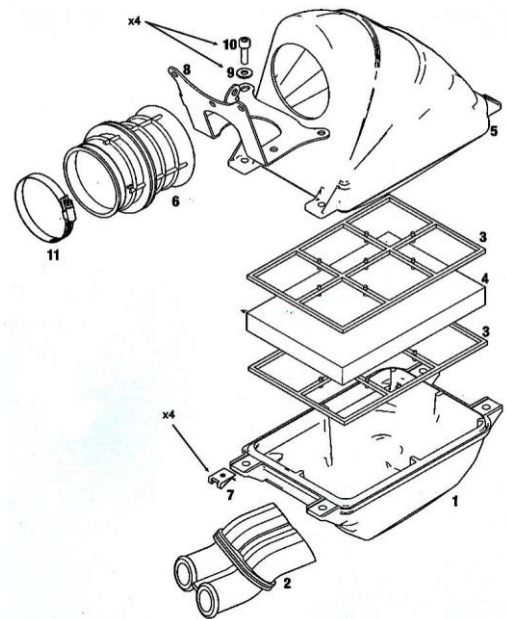

5.8 Carburettor

Dell'Orto carburettor, housing must show the cast wording "VHSB 34".

Carburettor housing is stamped with "XS".

The complete inlet bore of the carburettor must show cast surface.

Optional carburettor plug screw marked "ROTAX" (ROTAX 261 030) is legal to be used.

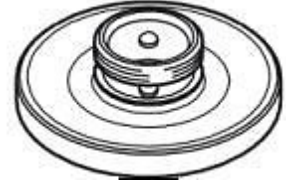

The two vent fittings must be connected with the original air vent hose min. 155mm (ROTAX 260260). The location of the opening has to be placed at the rear side of the carburettor

Settings of the carburettor adjustment screws (idle and idle air) are free.

The Position of the jet needle is free.

All jets must be correctly seated and securely fitted at any time and firmly tightened.

A minimum required size of main jet may be determined for each race event by a Bulletin.

The complete inlet bore of the carburettor housing must show cast surface.

The venturi hole of the carburettor insert can show signs of a CNC control machining.

Carburettor insert (venturi) may be used with 1 or 2 gaskets placed between the insert and the body of the carburettor.

Carburettor can be used with and without fuel sieve in the carburettor housing (highlighted in the picture).



The height of the two arms of the float lever must be within the slot of the carburettor gauge (ROTAX 277400) by their normal weight measured at carburettor housing without gasket in reverse upright Position.

Needle valve assembly stamped "150".

Needle of needle valve marked with diamond symbol "INC" only.

Start jet is stamped with the digits "60".

Any Dell'Orto main jet number even if not offered from Rotax is legal to be used.

Carburettor slide shows digits "45" in casting.

Jet needle must be stamped with "K57".



Two floats marked "4,0 gr" are legal to be used only.

Needle jet stamped with "DP267":

	Measurement	Tolerance
Total length	51.00mm	+0.50mm -0.50mm



	Measurement	Tolerance
Bottom section	33.00mm	+0.45mm -0.45mm



	Measurement	Tolerance
Top bore	2.67mm	+0.10mm -0.10mm



Idle jet must be stamped with "60". Plug gauge 0,65 must not enter the bore (use jet gauge set ROTAX 281 920).



Idle emulsion tube must be stamped with "45". Plug gauge 0,50 not enter the central bore (use jet gauge set ROTAX 281 920).



Atomiser:

Remove atomiser from carburettor body by means of venturi tool set (ROTAX 676 034).

	Measurement	Tolerance
Total length	23.75mm	+0.35mm -0.35mm



	Measurement	Tolerance
Cylindrical length	15.75mm	+0.25mm -0.25mm



	Measurement	Tolerance
Cutaway dimension	5.8mm	+0.30mm -0.30mm



	Measurement	Tolerance
Cross bore dimension	5.0mm	+0.15mm -0.15mm



Carburettor insert must show stamping: "12,5".



Angular bore of carburettor insert. Plug gauge 0,60 must not enter the bore (use jet gauge set ROTAX 281 920).



Vertical bore of carburettor insert. Plug gauge 1,30 must not enter the bore (use jet gauge set ROTAX 281 920).



125 Micro MAX (Micro Cadet) and 125 Mini MAX (Inter):

The throttle body restrictor must always be correctly installed and firmly in place with the plastic edge of the throttle body restrictor flush against the rear of the carburettor face at all times and in the correct orientation at all times (see picture for reference).

ROTAX part number: 267536.

No modifications are allowed, the ribbed surface on the inlet is to help ensure dimensions have not been modified.

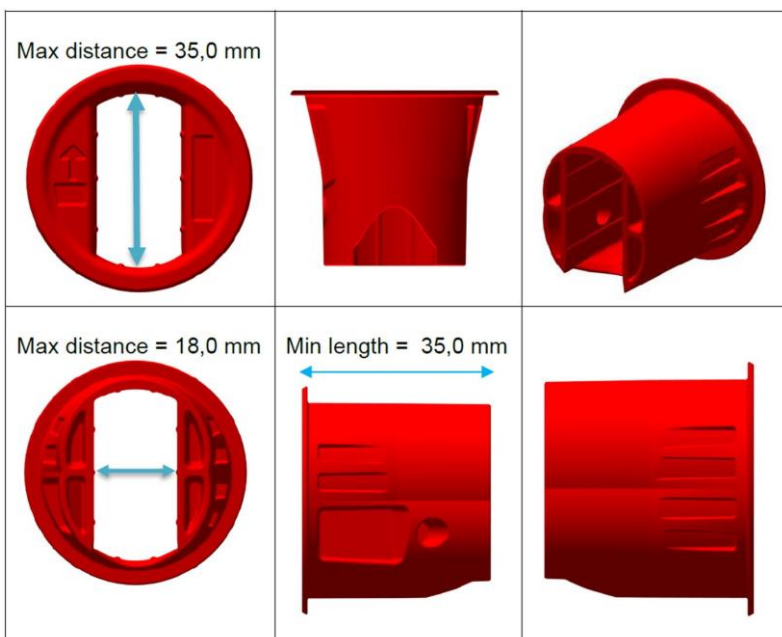

In addition to above an Inlet throttle restrictor must be in place at all times. The restrictor(s) must be as supplied by J.A.G. Engineering, no modifications are permitted. The total length of the inlet throttle restrictor must be 43mm minimum. The carburettor must be fully assembled with the inlet throttle restrictor (and washer where used) correctly installed. The carburettor cap must be fastened and in place and fixation plate (ROTAX 251790) must be correctly fitted and unmodified when in use. The ROTAX gauge (277400) must not touch the bronze atomiser in the centre of the carburettor venturi at any time when the throttle slide is fully open.

5.9 Fuel Pump

MIKUNI diaphragm pump, (see picture) must be used and must be mounted as shown in the illustration.

Fuel pump must be mounted on the bottom side of the support bracket for the intake silencer (see picture).

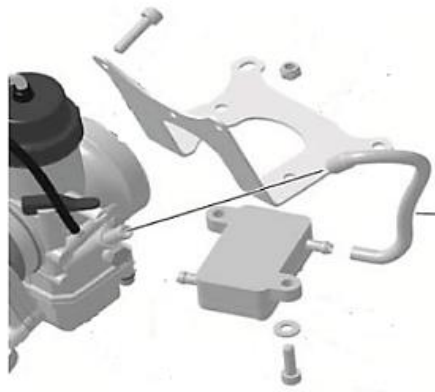

5.10 Fuel Filter

Two versions of original fuel filter are legal to be used (see pictures).

A fuel filter is mandatory to be installed. The fuel filter must be mounted between the fuel tank and the fuel pump.

Except the fuel line, the fuel pump and the original fuel filter no additional parts are permitted to be mounted between fuel tank and carburettor.



5.11 Radiator

The removal of the thermostat from the cylinder head cover is an allowed modification.

Radiator must be mounted with all components as shown in the respective illustration.

To apply tape around the radiator is an allowed modification to control the air flow through the radiator. Tape may not be removed from the radiator during operation on the track.

Any other non-original device to control the air flow through the radiator is prohibited.

The dimensions of the radiators are for reference purposes only.

125 Micro MAX (Micro Cadet) and 125 Mini MAX (Inter):

Two different versions as shown in the illustrations are legal to be used.

Cooling area: Height: 280-300mm
Width: 58-62mm

Thickness of radiator: 30-34mm

To remove the original flap is an allowed modification.

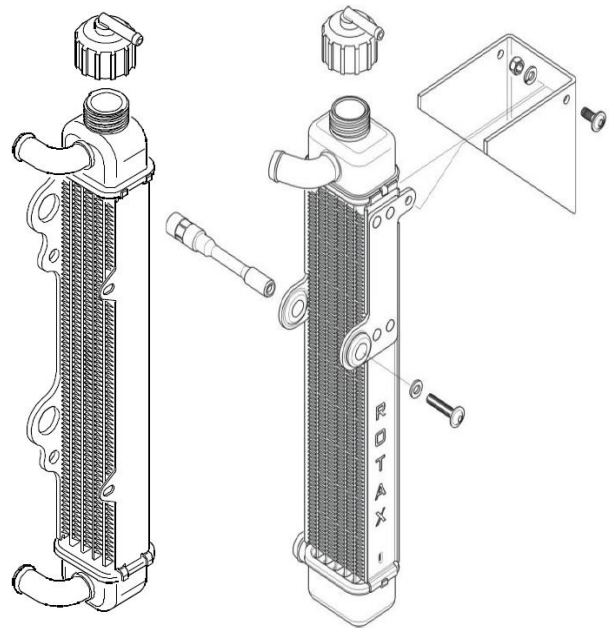

125 Junior MAX and 125 Senior MAX:

The radiator must be mounted on the right side of the engine.

Three different versions as shown in the illustrations are legal to be used.

Version 1: Cooling area: Height: 290mm
Width: 133mm

Thickness of radiator: 32mm

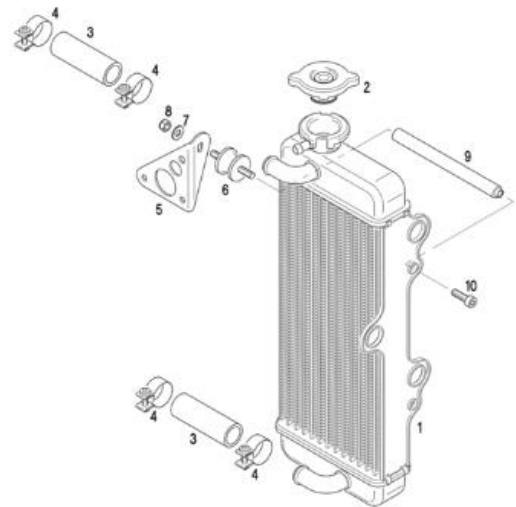

Version 2: Cooling area: Height: 290mm
Width: 133mm

Thickness of radiator: 32mm

The support plate (7) enables two different mounting positions (height) of the radiator. Both mounting positions are legal to be used.

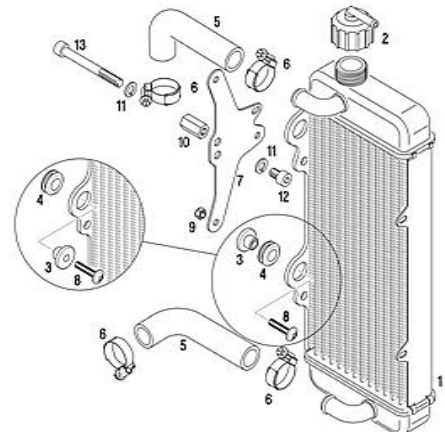

Version 3: Cooling area: Height: 290mm
Width: 138mm

Thickness of radiator: 34mm

Radiator must be stamped on the side with the wording "ROTAX".

To remove the original flap is an allowed modification.

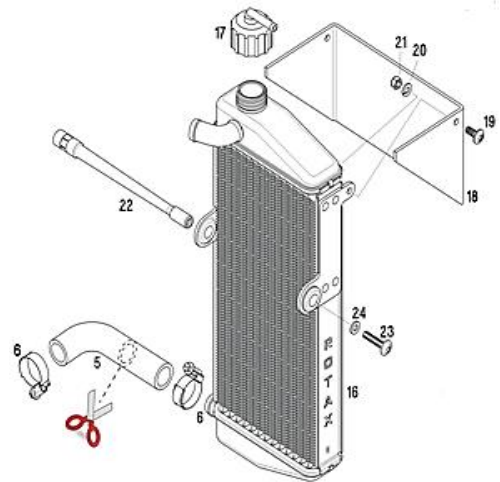

5.12 Engine Coolant

Plain water with or without additives may be used.

5.13 Exhaust Socket (Restrictor)

125 Micro MAX (Micro Cadet) and 125 Mini MAX (Inter):

Just exhaust sockets with gasket ring are legal to be used.

Diameter (A) must apply for a length (B) of at least 12mm.

Maximum inner diameter (A) of exhaust socket is:

125 Micro MAX (Micro Cadet): 18.30mm (ROTAX 273 192)

125 Mini MAX (Inter): 22.20mm (ROTAX 273 196)

The measurement (C) must be at minimum 18.50 mm.

The internal profile of the exhaust socket has to be checked with the template (ROTAX 277 405).

Fit the template (125 Micro MAX (Micro Cadet) "18mm", 125 Mini MAX (Inter) "22 mm") as far as possible into the exhaust socket (without gasket, carbon deposits removed). There has to be a constant crack light between the profile of the exhaust socket and the profile of the template.

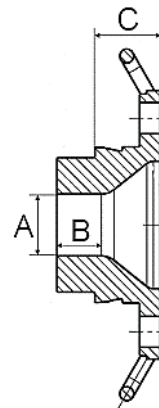

125 Junior MAX and 125 Senior MAX:

ROTAX part no. 273 190 must be used.

The measurement (C) must be at least 15.50 mm.

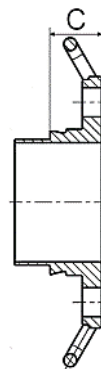

5.14 Exhaust System

The use of maximum 4 pieces of original Rotax exhaust springs, to fix the exhaust system to the cylinder is allowed. (a “safety wire” in the exhaust flange or silencer area is not allowed).

Original exhaust system as supplied by Rotax is mandatory to be used for the relevant class.

Welding at the exhaust system is only allowed in the case of a repair. Only repairs that return the components to its original shape or form are allowed.

Allowed modifications on the original exhaust systems are:

- Replacing the original rivets of the silencer end cap by 4mm metric screws and corresponding locking nuts. The 3 x fixations (rivets, bolts and locking nuts) must be always secured tight to ensure a sealing between the perforated tube and exhaust system. The perforated tube must be fully inserted into the exhaust system (see top right picture for reference) External protrusion of the outer sealing ring of the perforated tube is forbidden (indicated by the red arrow).
- If the event requires the exhaust / perforated tube to be sealed, the seal must be passed through a 4th hole (maximum 4mm diameter). The hole must be in a position that avoids the leaking of exhaust gasses as indicated in the picture on the right. The perforated tube must be always secured tightly to the exhaust at 3 points.
- Replacing the isolating mat (just one original isolating mat may be fitted) inside the silencer and the silencer end cap with perforated tube by original Rotax spares parts.
 - 125 Micro MAX (Micro Cadet): ROTAX 297982
 - 125 Mini MAX (Inter): ROTAX 297985
 - 125 Junior MAX: ROTAX 297982
 - 125 Senior MAX: ROTAX 297982



Note: For post-race technical scrutineering checks on the exhaust isolating mat, only the used weight is to be controlled.

The exhaust isolating mat new size and weight specifications can only be applied for pre-race/event technical checks against new material prior to installation and sealing of the exhaust system, if specified by the event/series organiser.

- Welding a socket (at a distance of 50-80 mm from the ball joint) on the top of the exhaust system for measuring the exhaust gas temperature.
- Addition extra elements after the original silencer for further noise reduction. Additional to the standard isolation mat a steel isolation mat (Rotax part no. 297 983) with the square dimension of 165 +10mm is legal for use in the Junior and Senior classes only (not mandatory) to be assembled underneath the standard isolation mat according to the illustration.

Clamp (1) must be fitted at a distance of 18 ± 2 mm, measured from the end of the tube.

Clamp (2) must be fitted at the end area of the steel isolation mat.

The measurement 10-12 mm from the end of the perforated tube to the beginning of the steel isolating mat is a specification for assembly purpose only!

Both clamps (1 and 2) are mandatory to be fitted and tightened.

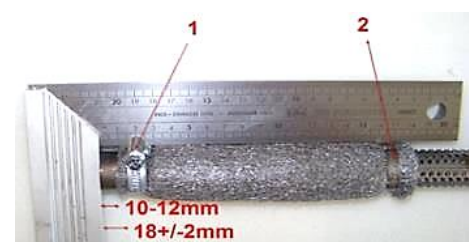

5.14.1 125 Micro MAX (Micro Cadet) & 125 Mini MAX (Inter) Exhaust

A specific exhaust system must be used:

- 125 Micro MAX (Micro Cadet) - ROTAX part number 273136
- 125 Mini MAX (Inter) – ROTAX part number 273137.

The exhaust external body is a common component for both engines, but with alternative internal components (inserts) detailed later.

The silencer must be mounted in a position where the direction of the 90° elbow outlet (direction of the hot exhaust gases) does not harm any component of the chassis.

The exhaust must be mounted and secured in such a way to ensure a full sealing around the exhaust socket and the gasket ring.

The measurements in the diagram to the right are as follows:

- (a) 580mm ± 5mm
- (b) 299mm ± 5mm
- (c) 42mm ± 3mm

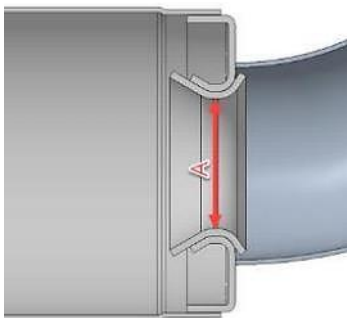
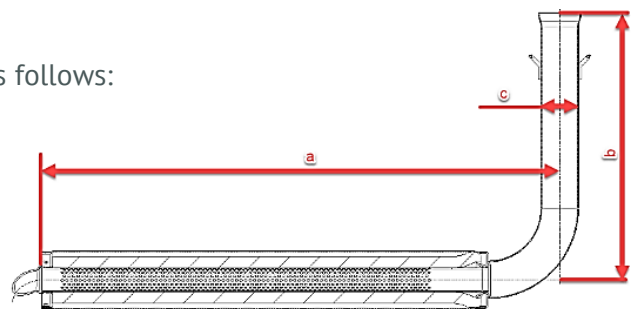

A steel ball with a 28.0mm diameter or solid flat plate measuring 28.0mm and 1.5mm thick must not pass through section A and a steel ball with a 26.0mm diameter must be able to pass through section A in the below diagram from the inlet and through the 90-degree elbow completely. All exhaust gases must pass through Section A. (Internal exhaust components must first be removed)

The inner measurement of the exhaust system silencer end (a) in the diagram must be a maximum of 63.0mm.

Note: This is not a measurement of the perforated tube.

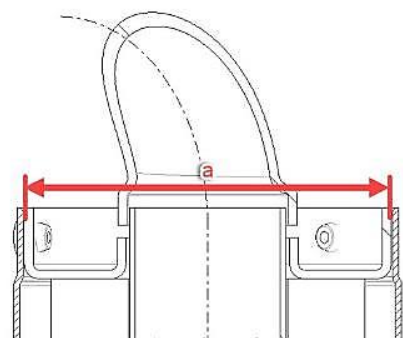

The exhaust must be installed firmly to the chassis using a rigid mount(s).

The exhaust must be mounted to the rigid mount(s) using 2 ROTAX silent blocks. (Part 660920 and/or 260657 allowed).

The deflection of the 2 silent blocks is the only exhaust movement allowed.

The exhaust must be mounted in a neutral position with no stress on the 2 silent blocks.

Note:

The only exhaust system allowed for racing in the 125 Micro MAX (Micro Cadet) and 125 Mini MAX (Inter) classes is the MY2020 version.

The exhaust has 3 clear visual differences to identify the MY2020 version:

1. Exhaust hooks
2. Connecting socket / ball joint connect at manifold
3. Wall thickness of the exhaust system is 1.0mm (older exhaust system which is not allowed for racing has a wall thickness of 1.5mm).

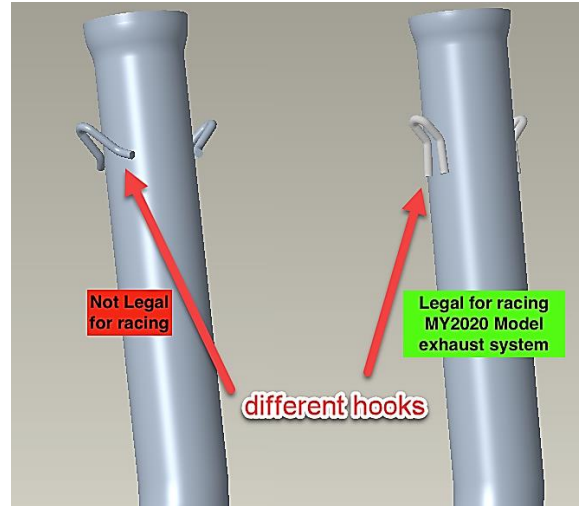

5.14.2 125 Micro MAX (Micro Cadet) Perforated Tube & Isolation Mat

Perforated tube ROTAX part number: 273212.

The measurements in the diagram to the right are as follows:

- (a) minimum 498mm
- (b) minimum outside diameter of 61mm
- (c) maximum outside diameter of 26mm
- (d) minimum length 63mm

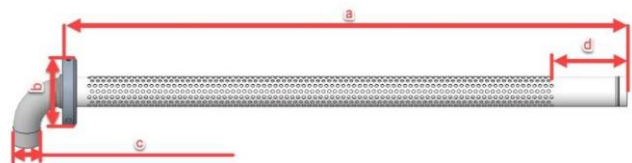

The measurement in the diagram to the right is as follows:

- (a) minimum outside diameter of 26.0mm



The only permitted isolation matting for 125 Micro MAX (Micro Cadet) is: ROTAX part number 297982.

	Measurement	Tolerance
New size minimum	480 x 270mm	+10mm
		-10mm
New weight	207g	+31g
		-31g
Used weight (old)	245g	+105g
		-105g

5.14.3 125 Mini MAX (Inter) Perforated Tube & Isolation Mat

Perforated tube ROTAX part number: 273211.

The measurements in the diagram to the right are as follows:

- (a) minimum 482mm
- (b) minimum outside diameter of 61 mm
- (c) maximum outside diameter of 26 mm
- (d) minimum length 63 mm

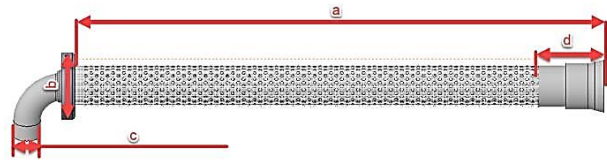

Note:

125 Mini MAX (Inter) perforated tube has a stamped ID marker “X” visible externally.



The only permitted isolation matting for 125 Mini MAX (Inter) is: ROTAX part number 297985.

	Measurement	Tolerance
New size minimum	490 x 180mm	+10mm
		-10mm
New weight	141g	+22g
		-22g
Used weight (old)	230g	+120g
		-120g

5.14.4 125 Junior MAX & 125 Senior MAX Exhaust

The silencer must be mounted in a position where the direction of the 90° elbow outlet (direction of the hot exhaust gases) does not harm any component of the chassis.

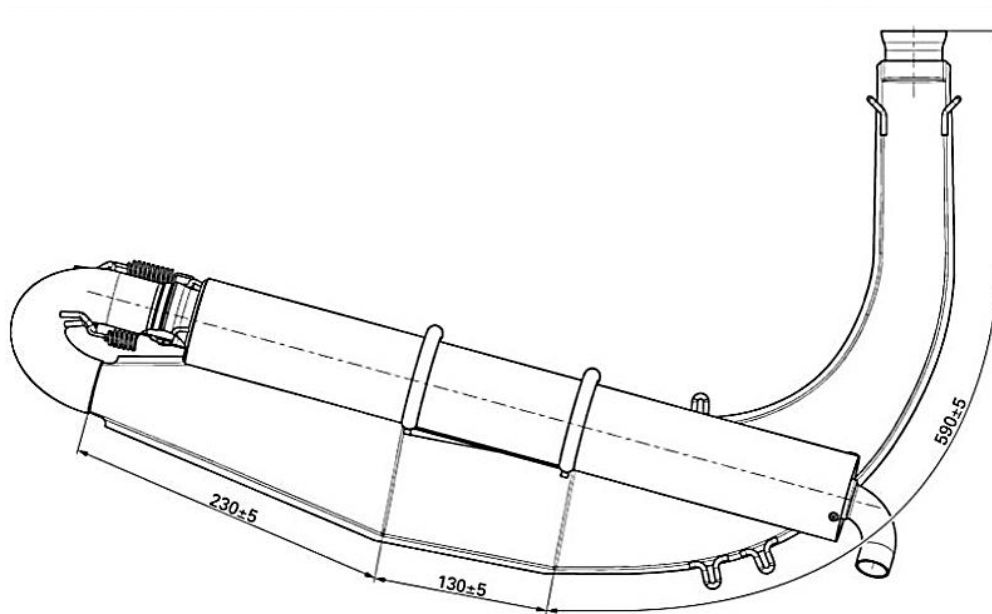

The only legal isolation matting for 125 Junior MAX and 125 Senior MAX is: ROTAX part number 297982.

	Measurement	Tolerance
New size minimum	480 x 270mm	+10mm
		-10mm
New weight	207g	+31g
		-31g
Used weight (old)	245g	+105g
		-105g